

24 HOUR MECHANICAL SOCKET BOX TIMER

inchronox

PRO SERIES by GREEN BROOK

Model: T100A

Please read the instructions fully before attempting installation.

IMPORTANT

This unit should be installed to current IET wiring regulations if in doubt consult a qualified electrician.

- Timer must not be mounted on a flammable surface.
- Ensure that the timer does not come into contact with any combustible materials such as towels or bedding.
- Ensure at least a 300mm air space is allowed around the timer.

INSTALLATION

- Prepare cable ends for connection to terminals.
- Remove the 2 screws holding the timeswitch cover to the backplate.
Remove cover leaving the timeswitch hanging loose by its connection wires to the backplate.

DO NOT INTERFERE WITH THESE FIXED CONNECTIONS.

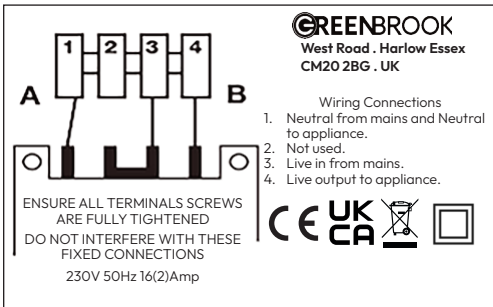

CONNECTION FOR 230V SWITCHED OUTPUT

1. Neutral from mains and Neutral to appliance.
2. Not used.
3. Live in from mains.
4. Live output to appliance.

WIRING

- Connect all earth wires to earthing point in wall box.
- Offer up the backplate to the wall box and connect the wiring as below.

IMPORTANT: Ensure all Terminal screws are fully tightened.

- When the wiring is complete screw the backplate to the fitted wall box using two 3.5mm screws.
- Push the timeswitch back in to its seating on the backplate, taking care that all the wires are tucked in. Fit the cover and tighten the two screws.

SETTING THE CLOCK

- Turn the dial in the direction of the arrow (clockwise) until the correct time of day is exactly opposite time set marker ▲ on the clock face. (24 hour clock).
- For the “ON” period push the switching riders out towards the outside edge of the face. The timer will operate for the duration set (each segment is approximately 15 minutes duration). i.e. If it is required to switch on between 16.00 and 18.00, all the segments between these times should be moved to the outer edge.

SETTING THE PROGRAMME

- By moving the switch located centre right of the dock face the following operations can be achieved.

- I = Permanently ON.
- = Switching programme as set on dial.
- 0 = Permanently OFF.

TECHNICAL INFORMATION

Switching Capacity:	230V AC, 16A Resistive, 2A Inductive
Ambient Temperature:	-10°C to + 55°C
Shortest Switching Time:	15 minutes
Wattage:	3000W
Conforms To:	BS EN 60730-1, BS EN 60730-2-7

CE INFORMATION

ACTION TYPE: IB

POLLUTION SITUATION: NORMAL

CLASS 2 INSULATION:

: MICRO-DISCONNECTION LIVE POLE ONLY

DIMENSIONS

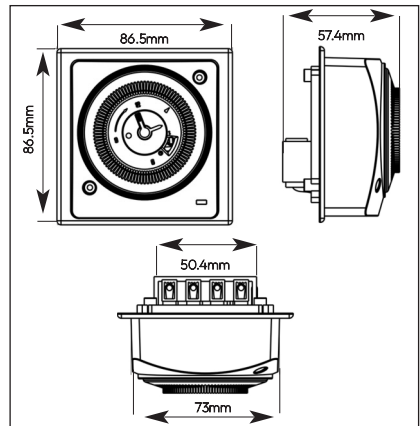

NOTE:

Product & Packaging Disposal

When disposing of this item and its packaging please follow local regulations and use an appropriate waste disposal centre.

See GreenBrook website for further details.

GUARANTEE

Your T100A 24hr Mechanical Timer is guaranteed for 1 year from the date of purchase.

This is in addition to your statutory rights.

PLEASE KEEP THESE INSTRUCTIONS SAFE FOR FUTURE REFERENCE

GREEN BROOK

WEST ROAD, HARLOW
ESSEX, CM20 2BG, UK
info@greenbrook.co.uk
www.greenbrook.co.uk

Issue no: 708270

CE UK CA

