

7 DAY ELECTRONIC SOCKET BOX TIMER

Model: T108A

inchronox

PRO
SERIES by GREEN
BROOK

Please read the instructions fully before attempting installation.

IMPORTANT

This unit should be installed to current IET wiring regulations if in doubt consult a qualified electrician.

- Timer must not be mounted on a flammable surface.
- Ensure that the timer does not come into contact with any combustible materials such as towels or bedding.
- Ensure at least a 300mm air space is allowed around the timer.

INSTALLATION

- Prepare cable ends for connection to terminals.
- Remove the 2 screws holding the timeswitch cover to the backplate.
Remove cover leaving the timeswitch hanging loose by its connection wires to the backplate.

DO NOT INTERFERE WITH THESE FIXED CONNECTIONS.

WIRING

- Connect all earth wires to earthing point in wall box.
- Offer up the backplate to the wall box and connect the wiring as shown in diagram below.

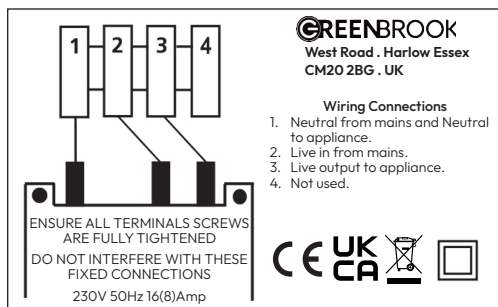

IMPORTANT:

Ensure all Terminal screws are fully tightened.

- When the wiring is complete screw the backplate to the fitted wall box using 3.5mm screws.
- Push the timeswitch back in to its seating on the backplate, taking care that all the wires are tucked in. Fit the cover and tighten the two screws.

CURRENT TIME AND DAY SETTING

1. When the timer is powered up set current time & day. If no display is showing leave on charge for 30 mins & display should then show, If not gently press the reset button.
2. Press Y to enter function setup. (Note: if another button is not pressed within 10 seconds the display will revert to the normal screen).
3. Use the + or - button to scroll to the clock icon (flashing) and press Y to enter the current time setting mode (hours flashing).

4. If you keep the + or - buttons pressed for more than 3 seconds, the display will enter fast scroll mode.
5. Use the + or - button to adjust the hours and press Y to confirm, minutes will flash.
6. Use the + or - button to adjust the minutes and press Y to confirm, day will flash.
7. Use the + or - button to adjust the day and press N to exit.

PROGRAMMING THE SWITCHING TIMES



1. There are 24 ON/OFF programmes available.
2. Press the Y button twice to enter the programming setting mode. (Note: if another button is not pressed within 10 seconds the display will revert to the normal screen).
3. Default is programme 01 ON, this can be changed if required by pressing + or - button to scroll through the 24 ON/OFF programmes as required, pressing the Y will confirm the programme.
4. Press the Y button to confirm programme 01 ON, hours will flash.
5. Use the + or - button to adjust the hours and press Y to confirm, minutes will flash.
6. Use the + or - button to adjust the minutes and press Y to confirm, days will flash.
7. Apart from individual days of the week, the following day combinations of multiple day blocks can be selected by pressing the + or - buttons.
 - Monday to Sunday
 - Monday to Friday
 - Saturday to Sunday
 - Monday to Saturday
 - Monday + Wednesday + Friday
 - Tuesday + Thursday + Saturday
 - Monday + Tuesday + Wednesday
 - Thursday + Friday + Saturday
8. Select day or day block as required and press the Y button to confirm.
9. Press the + button, this will select the programme 01 OFF, press Y to confirm.
10. Follow 4 to 7 above to set the 01 OFF programme (day or day block must be the same as programme ON).
11. If no more programmes are required, press the N button to exit.
12. If more programmes are required follow 3 above.
13. To cancel a programme once set, press and hold the N button for more than 3 seconds when the desired programme number is flashing i.e. to cancel programme 01 ON, press the Y button twice and hold the N button down for more than 3 seconds to delete. Pressing the + button again will select 01 OFF.
14. Repeat 13 to delete 01 OFF. This procedure can be repeated to delete any of the 24 programmes.

TIMER COUNTDOWN FUNCTION

1. Timer has a 100 hour countdown feature i.e. the timer can be set to any period from 1 minute to 100 hours and will countdown in the ON state and turn OFF at the end of the countdown period.
2. Press the Y button then use the + or - button to select the "down" icon on the right hand side of the display, press Y again to enter the countdown mode.

- Use the + or - button to adjust the hours and press Y to confirm. minutes will flash.
- Use the + or - button to adjust the minutes and press Y to confirm and complete the countdown time setting.
- Press the N button to start the countdown.
- Output switched to ON during the countdown period.
- Press the N button to pause the countdown (output switched to OFF)
- To resume countdown simply press the N button again.
- Press and hold the N button for more than 3 seconds to exit the countdown function.

MANUAL OVERRIDE

- When in normal clock mode, pressing the N button will scroll through the following switching options.
 - ALWAYS ON - timer is permanently ON.
 -  PROG - timer is in programme ON mode, will switch off at the next programme OFF time.
 - ALWAYS OFF - timer is permanently OFF.
 - PROG  - timer is in programme OFF mode, will switch on at the next programme ON time.

SUMMER TIME SETTING

- Press the Y button, then use the + or - buttons to scroll through to "summer" (flashing).
- Press the Y button again to access the summer time setting.
- Press the + or - button to change between summer on or off.
- Press Y to confirm summer setting, time will advance 1 hour.
- A "SUMMER" icon will appear in the display.
- Use the same procedure to remove the "SUMMER" icon when reverting to GMT in the winter.

RANDOM SETTING

The random setting allows the timer to switch ON and OFF with a random delay of between 2 and 32 minutes. This function will only operate if one or more programmes have been programmed into the timer.

- Press the Y button, then use the + or - buttons to scroll through to "RANDOM" (flashing).
- Press the Y button again to access the random setting.
- Pressing the + or - buttons will toggle the random icon on and off.
- Press the Y button to confirm random function.
- A "RANDOM" function icon will appear in the display.
- Timer will now operate in the random mode.
- To cancel random feature use the procedure above to remove the "RANDOM" icon from the display.

READING YOUR PROGRAMMED TIMES

- Press Y button twice to enter programme mode.
- Press the + or - buttons to scroll through the 24 ON/OFF programmes to check settings.
- Press the N button to exit and revert to clock mode.

RESET

Pressing the reset button R with a pencil or similar will reset all programmed times and set time of day to zero.

IMPORTANT:

- When you have completed the programme settings ensure you set the correct operating mode as shown in manual override.
- Do not leave uncharged for more than 6 months.

TECHNICAL INFORMATION

Switching Capacity:	230V AC, 16A Resistive, 8A Inductive
Battery Back Up:	150 hours
Ambient Temperature:	-10°C to + 55°C
Shortest Switching Time:	1 minute
Wattage:	3000W
Conforms To:	BS EN 60730-1, BS EN 60730-2-7

CE INFORMATION

ACTION TYPE: IB

POLLUTION SITUATION: NORMAL

CLASS 2 INSULATION: 

 : MICRO-DISCONNECTION LIVE POLE ONLY

DIMENSIONS

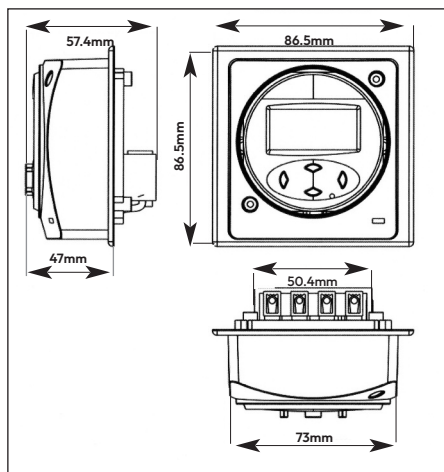

NOTE:

Product & Packaging Disposal

When disposing of this item and its packaging please follow local regulations and use an appropriate waste disposal centre.

See GreenBrook website for further details.

GUARANTEE

Your T108A 7 Day Electronic Timer is guaranteed for 1 year from the date of purchase. This is in addition to your statutory rights.

PLEASE KEEP THESE INSTRUCTIONS SAFE FOR FUTURE REFERENCE

GREEN BROOK

WEST ROAD, HARLOW
ESSEX, CM20 2BG, UK
info@greenbrook.co.uk
www.greenbrook.co.uk

Issue no: 708276

CE UK CA

