

ReAchSafe Swingback Ladder Range

BS EN131 Fibreglass Step Ladders

TECHNICAL DATASHEET

CORE SERIES

FEATURES

- ▶ Fibreglass ladder rails are non-conductive - safer for working around electricity
- ▶ Lightweight, strong, heat and weather resistant
- ▶ Durable - offers excellent resistance to denting and bending
- ▶ Safety secure tools at working height using the multi-fuctional top
- ▶ Non-slip steps and rubber non-slip feet for greater safety
- ▶ Conforms to BS EN 131-1-2-3 for professional use
- ▶ Voltage tested to 35,000V

81mm wide deep serrated slip-resistant steps

TECHNICAL INFO

Product	LAD4	LAD5	LAD6	LAD7	LAD8	LAD9	LAD10
Material	Fibre Glass						
Description	No of Steps 3 Usable Steps 1	No of Steps 4 Usable Steps 2	No of Steps 5 Usable Steps 3	No of Steps 6 Usable Steps 4	No of Steps 7 Usable Steps 5	No of Steps 8 Usable Steps 6	No of Steps 9 Usable Steps 7
Product Weight	6.1kg	7.5kg	8.7kg	10.5kg	11.6kg	13.7kg	14.9kg
Barcode	5012739 650567	5012739 650574	5012739 650581	5012739 650598	5012739 650604	5012739 650611	5012739 650628
Guarantee	1 Year						
Conforms To	BS EN 131-1-2-3						



LAD6
Max Load 150Kg



GreenBrook Swingback ladders are now TUV GS approved



Ladder feet with improved grip for greater anti-slip protection



Multi-functional top



Please see overleaf for full ladder specification

ReAchSafe Swingback Ladder Range

BS EN131 Fibreglass Step Ladders

TECHNICAL DATASHEET

CORE SERIES

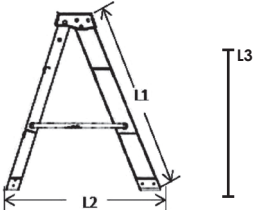
LAD4	
	
No of Steps	3
Usable Steps	1
Weight	6.1kg
Max Load	150kg
L1 (mm)	1140
L2 (mm)	875
Pack Size (mm) (inc packaging)	L1213 X W(top)350 W(bottom)485 x D 160
Open Height (mm)	1060
L3 Usable Step Height (mm)	270

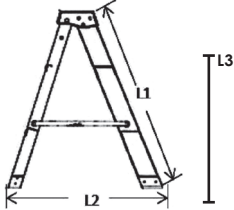
LAD5	
	
No of Steps	4
Usable Steps	2
Weight	7.5kg
Max Load	150kg
L1 (mm)	1440
L2 (mm)	1070
Pack Size (mm) (inc packaging)	L1513 X W(top)350 W(bottom)515 x D 160
Open Height (mm)	1337
L3 Usable Step Height (mm)	547

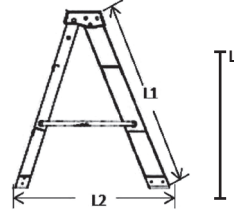
LAD6	
	
No of Steps	5
Usable Steps	3
Weight	8.7kg
Max Load	150kg
L1 (mm)	1740
L2 (mm)	1265
Pack Size (mm) (inc packaging)	L1812 X W(top)350 W(bottom)558 x D 160
Open Height (mm)	1615
L3 Usable Step Height (mm)	825

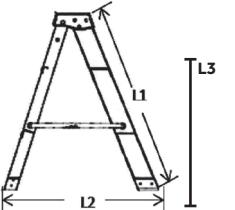

LAD7	
	
No of Steps	6
Usable Steps	4
Weight	10.5kg
Max Load	150kg
L1 (mm)	2040
L2 (mm)	1465
Pack Size (mm) (inc packaging)	L2112 X W(top)350 W(bottom)595 x D 160
Open Height (mm)	1893
L3 Usable Step Height (mm)	1104

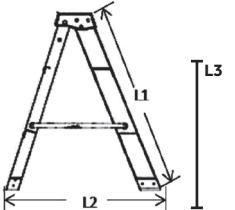
LAD8	
	
No of Steps	7
Usable Steps	5
Weight	11.6kg
Max Load	150kg
L1 (mm)	2340
L2 (mm)	1665
Pack Size (mm) (inc packaging)	L2411 X W(top)350 W(bottom)630 x D 160
Open Height (mm)	2170
L3 Usable Step Height (mm)	1382

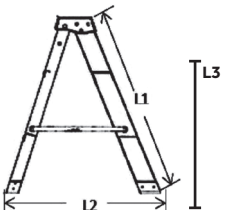
LAD9	
	
No of Steps	8
Usable Steps	6
Weight	13.7kg
Max Load	150kg
L1 (mm)	2640
L2 (mm)	1855
Pack Size (mm) (inc packaging)	L2711 X W(top)350 W(bottom)668 x D 160
Open Height (mm)	2450
L3 Usable Step Height (mm)	1660

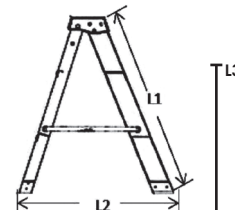
LAD10	
	
No of Steps	9
Usable Steps	7
Weight	14.9kg
Max Load	150kg
L1 (mm)	2940
L2 (mm)	2055
Pack Size (mm) (inc packaging)	L3010 X W(top)350 W(bottom)700 x D 160
Open Height (mm)	2727
L3 Usable Step Height (mm)	1938