

# powerbreaker

consumer units

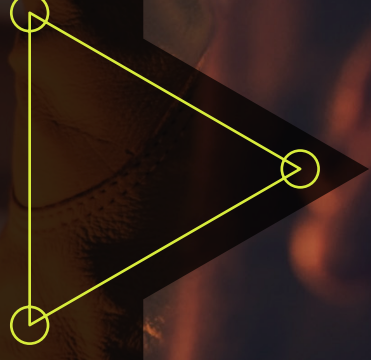

## Consumer Unit with Main Switch

The Part Populated Consumer Unit range available in 8 Board layouts with and without SPD - 8/10/12/14/16/18/20/22 module units.

- 2P Mains Switch 100A
- 1 x Neutral for use with RCBO Module
- 6kA Rated Short Circuit Capacity
- Label kit
- Grommet Strip
- 2 x Blanking modules supplied per board
- Conforms to BS EN 61439-3
- 3 year Guarantee



Code	Description
PBPM08	8 Module (100A Mains Switch) 6 Usable Ways
PBPM10	10 Module (100A Mains Switch) 8 Usable Ways
PBPM12	12 Module (100A Mains Switch) 10 Usable Ways
PBPM14	14 Module (100A Mains Switch) 12 Usable Ways
PBPM16	16 Module (100A Mains Switch) 14 Usable Ways
PBPM18	18 Module (100A Mains Switch) 16 Usable Ways
PBPM20	20 Module (100A Mains Switch) 18 Usable Ways
PBPM22	22 Module (100A Mains Switch) 20 Usable Ways

## Consumer Unit with Mains Switch with SPD - Type 2

- 2P Mains Switch 100A
- 1 x Neutral for use with RCBO Module
- 6kA Rated Short Circuit Capacity
- SPD Type 2
- SPD Protection (32A MCB)
- Label kit
- Grommet Strip
- 2 x Blanking modules supplied per board
- Conforms to BS EN 61439-3
- 3 year Guarantee

Suitable for TN - (TN-S, TN-C, TN-C-S) and TT



Code	Description
PBPM08-SPD	8 Module (100A Mains Switch) SPD Type 2 4 Usable Ways
PBPM10-SPD	10 Module (100A Mains Switch) SPD Type 2 6 Usable Ways
PBPM12-SPD	12 Module (100A Mains Switch) SPD Type 2 8 Usable Ways
PBPM14-SPD	14 Module (100A Mains Switch) SPD Type 2 10 Usable Ways
PBPM16-SPD	16 Module (100A Mains Switch) SPD Type 2 12 Usable Ways
PBPM18-SPD	18 Module (100A Mains Switch) SPD Type 2 14 Usable Ways
PBPM20-SPD	20 Module (100A Mains Switch) SPD Type 2 16 Usable Ways
PBPM22-SPD	22 Module (100A Mains Switch) SPD Type 2 18 Usable Ways

## Dual Consumer Unit with RCD and Main Switch

The Part Populated Consumer Unit range available in 5 Board layouts with and without SPD - 14/16/18/20/22 module units.

- **2P Main Switch 100A**
- **2 x RCCB 80A (Board sizes 14/16/18)**
- **2 x RCCB 100A (Board sizes 20/22)**
- **3 x Neutral Bars**
- **6kA Rated Short Circuit Capacity**
- **Label kit**
- **Grommet Strip**
- **Conforms to BS EN 61439-3**
- **3 year Guarantee**



Code	Description
<b>PBPDM14</b>	14 Module (2 x 80A 30mA RCCB Type A) 8 Usable Ways
<b>PBPDM16</b>	16 Module (2 x 80A 30mA RCCB Type A) 10 Usable Ways
<b>PBPDM18</b>	18 Module (2 x 80A 30mA RCCB Type A) 12 Usable Ways
<b>PBPDM20</b>	20 Module (2 x 100A 30mA RCCB Type A) 14 Usable Ways
<b>PBPDM22</b>	22 Module (2 x 100A 30mA RCCB Type A) 16 Usable Ways

## Consumer Unit Dual RCD with SPD

- **2P Main Switch 100A**
- **2 x RCCB 80A (Board sizes 14/16/18)**
- **2 x RCCB 100A (Board sizes 20/22)**
- **3 x Neutral Bars**
- **6kA Rated Short Circuit Capacity**
- **SPD Type 2**
- **SPD Protection (32A MCB)**
- **Label kit**
- **Grommet Strip**
- **Conforms to BS EN 61439-3**
- **3 year Guarantee**



Code	Description
<b>PBPDM14-SPD</b>	14 Module SPD Type 2 (2 x 80A 30mA RCCB Type A 6 Usable Ways)
<b>PBPDM16-SPD</b>	16 Module SPD Type 2 (2 x 80A 30mA RCCB Type A 8 Usable Ways)
<b>PBPDM18-SPD</b>	18 Module SPD Type 2 (2 x 80A 30mA RCCB Type A 10 Usable Ways)
<b>PBPDM20-SPD</b>	20 Module SPD Type 2 (2 x 100A 30mA RCCB Type A 12 Usable Ways)
<b>PBPDM22-SPD</b>	22 Module SPD Type 2 (2 x 100A 30mA RCCB Type A 14 Usable Ways)

# Double Bank Consumer Units

The Part Populated Consumer Unit range available in 3 Board layouts with and without SPD - 28 / 36 / 44 module units.

- **2P Mains Switch 100A**
- **3 x Neutral Bars**
- **6kA Rated Short Circuit Capacity**
- **Label kit**
- **Grommet Strip**
- **Conforms to BS EN 61439-3**
- **3 year Guarantee**



Code	Description
<b>PBDS28</b>	28 Module (100A Mains Switch) 25 Usable Ways
<b>PBDS36</b>	36 Module (100A Mains Switch) 33 Usable Ways
<b>PBDS44</b>	44 Module (100A Mains Switch) 41 Usable Ways

Suitable for TN - (TN-S, TN-C, TN-C-S) and TT

- **2P Mains Switch 100A**
- **3 x Neutral Bars**
- **6kA Rated Short Circuit Capacity**
- **SPD Type 2**
- **SPD Protection (32A MCB)**
- **Label kit**
- **Grommet Strip**
- **Conforms to BS EN 61439-3**
- **3 year Guarantee**

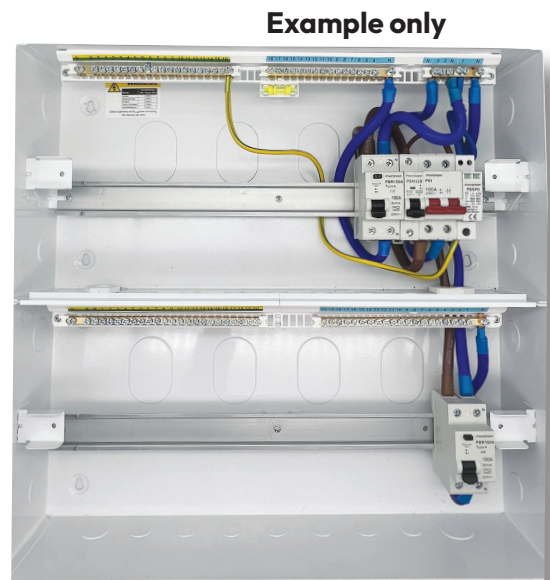

Code	Description
<b>PBDS28-SPD</b>	28 Module (100A Mains Switch) 23 Usable Ways
<b>PBDS36-SPD</b>	36 Module (100A Mains Switch) 31 Usable Ways
<b>PBDS44-SPD</b>	44 Module (100A Mains Switch) 39 Usable Ways

\* Product design may differ from those shown

# Dual Fully Populated Consumer Units

The Dual Fully Populated Consumer Unit range is available in 5 Board layouts - 14/16/18/20/22 modules.

- **2P Mains Switch 100A**
- **2 x RCCB 80A (Board sizes 14/16/18)**
- **2 x RCCB 100A (Board sizes 20/22)**
- **3 x Neutral bars**
- **6kA Rated Short Circuit Capacity**
- **Blank Modules 18 2 x Blanks**  
**Modules 20 4 x Blanks**  
**Modules 22 6 x Blanks**
- **MCB's - each board supplied with MCB's full details below**
- **Label kit**
- **Grommet Strip**
- **Conforms to BS EN 61439-3**
- **3 year Guarantee**

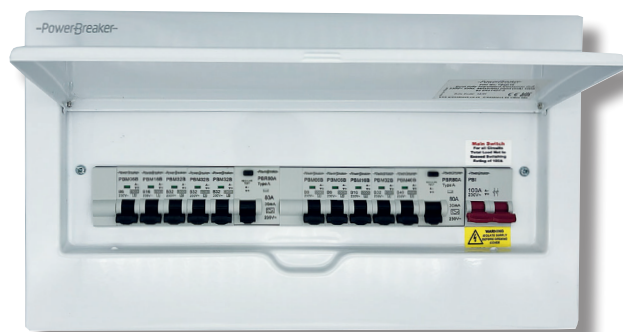

KEY - Consumer Unit Board Modules			
Blanking Module	MCB	RCCB (RCD)	Main Switch

Code	Description & Board Layout																			
<b>PBPD14</b>	14 Module (2 x 80A 30mA RCCB Type A) (8 MCBs, 1x 40A, 3 x 32A, 1x 16A, 3 x 6A)																			
<b>Board Layout</b>	<table border="1"> <tr> <td>6A</td><td>16A</td><td>32A</td><td>32A</td><td></td><td></td><td>6A</td><td>6A</td><td>32A</td><td>40A</td><td></td><td></td><td></td><td></td> </tr> </table>	6A	16A	32A	32A			6A	6A	32A	40A									
6A	16A	32A	32A			6A	6A	32A	40A											
<b>PBPD16</b>	16 Module (2 x 80A 30mA RCCB Type A) (10 MCBs, 1x 40A, 4 x 32A, 2 x 16A, 3 x 6A)																			
<b>Board Layout</b>	<table border="1"> <tr> <td>6A</td><td>16A</td><td>32A</td><td>32A</td><td>32A</td><td></td><td></td><td>6A</td><td>6A</td><td>16A</td><td>32A</td><td>40A</td><td></td><td></td><td></td> </tr> </table>	6A	16A	32A	32A	32A			6A	6A	16A	32A	40A							
6A	16A	32A	32A	32A			6A	6A	16A	32A	40A									
<b>PBPD18</b>	18 Module (2 x 80A 30mA RCCB Type A) (10 MCBs, 1x 40A, 4 x 32A, 2 x 16A, 3 x 6A)																			
<b>Board Layout</b>	<table border="1"> <tr> <td></td><td>6A</td><td>16A</td><td>32A</td><td>32A</td><td>32A</td><td></td><td></td><td>6A</td><td>6A</td><td>16A</td><td>32A</td><td>40A</td><td></td><td></td><td></td> </tr> </table>		6A	16A	32A	32A	32A			6A	6A	16A	32A	40A						
	6A	16A	32A	32A	32A			6A	6A	16A	32A	40A								
<b>PBPD20</b>	20 Module (2 x 100A 30mA RCCB Type A) (10 MCBs, 1x 40A, 4 x 32A, 2 x 16A, 3 x 6A)																			
<b>Board Layout</b>	<table border="1"> <tr> <td></td><td></td><td>6A</td><td>16A</td><td>32A</td><td>32A</td><td>32A</td><td></td><td></td><td>6A</td><td>6A</td><td>16A</td><td>32A</td><td>40A</td><td></td><td></td><td></td> </tr> </table>			6A	16A	32A	32A	32A			6A	6A	16A	32A	40A					
		6A	16A	32A	32A	32A			6A	6A	16A	32A	40A							
<b>PBPD22</b>	22 Module (2 x 100A 30mA RCCB Type A) (10 MCBs, 1x 40A, 4 x 32A, 2 x 16A, 3 x 6A)																			
<b>Board Layout</b>	<table border="1"> <tr> <td></td><td></td><td></td><td>6A</td><td>16A</td><td>32A</td><td>32A</td><td>32A</td><td></td><td></td><td></td><td>6A</td><td>6A</td><td>16A</td><td>32A</td><td>40A</td><td></td><td></td><td></td> </tr> </table>				6A	16A	32A	32A	32A				6A	6A	16A	32A	40A			
			6A	16A	32A	32A	32A				6A	6A	16A	32A	40A					

# Dual Consumer Unit with Type 2 SPD

The Dual Consumer Unit range are available in 3 Board layouts  
 - 16 modules / 18 modules / 22 modules



- 2P Mains Switch 100A
- 2 x RCCB 80A (Board sizes 16/18)
- 2 x RCCB 100A (Board sizes 22)
- 3 x Neutral Bars
- 6kA Rated Short Circuit Capacity
- SPD Type 2
- SPD Protection (32A MCB)
- MCB's - each board supplied with MCB's full details below
- Label kit
- Grommet Strip
- Conforms to BS EN 61439-3
- 3 year Guarantee

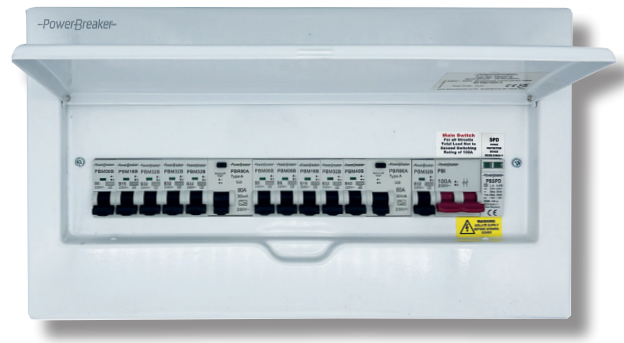

Suitable for TN - (TN-S, TN-C, TN-C-S) and TT

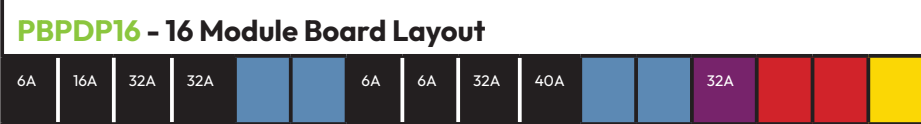
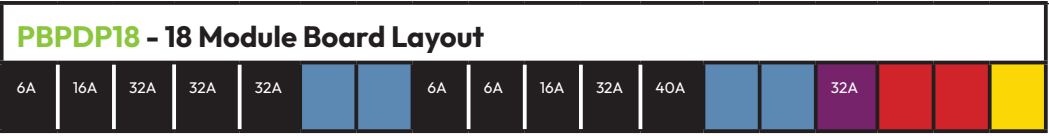

KEY - Consumer Unit Board Modules					
Blanking Module	MCB	RCCB (RCD)	32A MCB for SPD	Main Switch	SPD

Code	Description & Board Layout
<b>PBPD16</b>	16 Module, SPD Type 2, (2 x 80A 30mA RCCB Type A) (8 MCB's, 1 x 40A, 3 x 32A, 1 x 16A, 3 x 6A)
Board Layout	<b>PBPD16 - 16 Module Board Layout</b> 
<b>PBPD18</b>	18 Module, SPD Type 2 (2 x 80A 30mA RCCB Type A) (10 MCB's, 1 x 40A, 4 x 32A, 2 x 16A, 3 x 6A)
Board Layout	<b>PBPD18 - 18 Module Board Layout</b> 
<b>PBPD22</b>	22 Module SPD Type 2 (2 x 100A 30mA RCCB TYPE A) (10 MCB's, 1 x 40A, 4 x 32A, 2 x 16A, 3 x 6A, 4 Blanking Modules)
Board Layout	<b>PBPD22 - 22 Module Board Layout</b> 

# Dual High Integrity Consumer Unit with Type 2 SPD



The Dual High Integrity Consumer Unit range are available in 2 Board layouts  
 - 18 modules / 22 modules

- 2P Mains Switch 100A
- 2 x RCCB 100A
- 3 x Neutral Bars
- 6kA Rated Short Circuit Capacity
- SPD Type 2
- SPD Protection (32A MCB) supplied
- MCB's - each board supplied with MCB's full details below
- Spaces for RCBOs
- Blanks: - Modules 18 2 x Blanks  
                   Modules 22 4 x Blanks
- Label kit
- Grommet Strip
- Conforms to BS EN 61439-3
- 3 year Guarantee



Suitable for TN - (TN-S, TN-C, TN-C-S) and TT

KEY - Consumer Unit Board Modules						
Blanking Module	MCB	RCCB (RCD)	Space for RCBO	32A MCB for SPD	Main Switch	SPD

Code	Description & Board Layout
<b>PBPH18</b>	18 Module SPD Type 2 (2 x 100A 30mA RCCB Type A) (8 MCB's, 1 x 40A, 3 x 32A, 1 x 16A, 3 x 6A)
Board Layout	<p><b>PBPH18 - 18 Module Board Layout</b></p> 
<b>PBPH22</b>	22 Module SPD Type 2 (2 x 100A 30MA RCCB Type A) (10 X MCB's, 1 x 40A, 4 x 32A, 2 x 16A, 3 x 6A)
Board Layout	<p><b>PBPH22 - 22 Module Board Layout</b></p> 

## Garage Consumer Unit

- RCCB 63A, 30mA
- MCB's details below
- Grommet Strip
- Conforms to BS EN61439-3
- 3 year Guarantee

The PBGU is supplied with 63A RCCB and 2 MCB's 1 x 6A & 1 x 16A



Code	Description
PBGU	Garage Consumer Unit (63A, 30mA RCCB Type A) 1 x 6A & 1 x 16A MCB

## Shower Consumer Unit

- RCCB 63A, 30mA
- MCB's details below
- Grommet Strip
- Conforms to BS EN61439-3
- 3 year Guarantee

The PBSU is supplied with 63A RCCB and 1 x 50A MCB



Code	Description
PBSU	Shower Consumer Unit (63A, 30mA RCCB Type A) 1 x 50A MCB

### Shower & Garage Consumer Unit

For - PBSU & PBGU

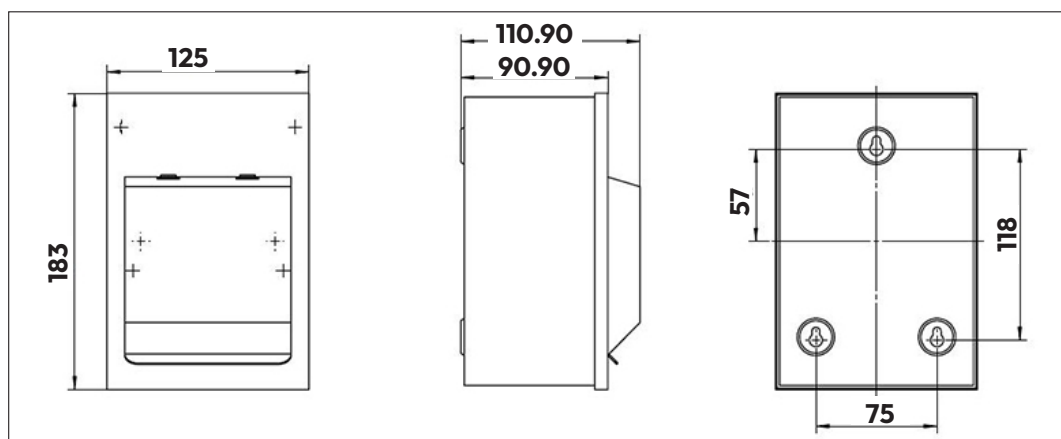

## EV Charger Unit

- 2 Pole Mains Switch 100A
- 6 Module unit
- 1 Free module
- SPD Type 2
- SPD Protection (32A MCB)
- 1P + N (Switch Neutral) RCBO
- Conforms to BS EN61439-3
- 3 year Guarantee



Code	Description
<b>PB6EV32-SPD</b>	2P 100A Mains Switch, 32A 2 Pole RCBO 30mA Type A SPD Type 2 Blanking Module
<b>PB6EV40-SPD</b>	2P 100A Mains Switch, 40A 2 Pole RCBO 30mA Type A SPD Type 2 Blanking Module

- 2 Pole Mains Switch 100A
- 4 Module Unit
- 1 Free module
- 1P + N (Switch Neutral) RCBO
- Conforms to BS EN61439-3
- 3 year Guarantee

Code	Description
<b>PB4EV32</b>	2P 100A Mains Switch, 32A 2 Pole RCBO 30mA Type A Blanking Module
<b>PB4EV40</b>	2P 100A Mains Switch, 40A 2 Pole RCBO 30mA Type A SPD Blanking Module

# RCCB Range

## Type A RCD

- Tripping is ensured for residual sinusoidal alternating currents and residual pulsating direct currents, whether suddenly applied or slowly rising.



<b>Pack Quantity</b>	1
<b>Number of Poles</b>	2P (Double Pole)
<b>Rated Voltage</b>	230/240VAC
<b>Rated Residual Current</b>	30mA
<b>Type of Residual Current</b>	Type A
<b>Rated Frequency</b>	50/60Hz
<b>Rated Short-Circuit Capacity</b>	6kA
<b>Index of Protection</b>	IP20
<b>Terminals</b>	1 - 35mm <sup>2</sup>
<b>Mechanical Endurance</b>	10,000 times
<b>Electrical Endurance</b>	4,000 times
<b>Ambient Temperature</b>	- 25°C to +55°C
<b>Storage Temperature</b>	- 40°C to +70°C
<b>Torque (Recommended minimum tightening)</b>	2.5Nm
<b>Din Rail Mounting</b>	Yes
<b>Guarantee</b>	5 Years
<b>Conforms To</b>	BS EN 61009

Code	Description
<b>PBR63A</b>	63A, 30mA RCCB Type A 2P
<b>PBR80A</b>	80A, 30mA RCCB Type A 2P
<b>PBR100A</b>	100A, 30mA RCCB Type A 2P

## MCB - B Curve

**Type B Curve -** Type B instantaneous tripping curve is used for the protection of circuits and equipment that have low surge currents

Devices are designed to trip at instantaneous fault currents of 3 - 5 times rated (In). For example a 10A device will trip at 30-50A instantaneous current.

<b>Pack Quantity</b>	12
<b>Number of Poles</b>	1P (Single Pole)
<b>Rated Voltage</b>	230/240VAC
<b>Rated Frequency</b>	50/60Hz
<b>Rated Short-Circuit Capacity</b>	6kA
<b>Tripping Characteristics</b>	Type B
<b>Index of Protection</b>	IP20
<b>Terminals</b>	1 - 25mm <sup>2</sup>
<b>Mechanical Endurance</b>	10,000 times
<b>Electrical Endurance</b>	4,000 times
<b>Ambient Temperature</b>	- 25°C to +55°C
<b>Storage Temperature</b>	- 40°C to +70°C
<b>Torque (Recommended minimum tightening)</b>	2.0Nm
<b>Din Rail Mounting</b>	Yes
<b>Guarantee</b>	5 Years
<b>Conforms To</b>	BS EN 60898-1



Code	Description
<b>PBM06B</b>	6A B Curve MCB 6kA 1P
<b>PBM10B</b>	10A B Curve MCB 6kA 1P
<b>PBM16B</b>	16A B Curve MCB 6kA 1P
<b>PBM20B</b>	20A B Curve MCB 6kA 1P
<b>PBM32B</b>	32A B Curve MCB 6kA 1P
<b>PBM40B</b>	40A B Curve MCB 6kA 1P
<b>PBM50B</b>	50A B Curve MCB 6kA 1P
<b>PBM63B</b>	62A B Curve MCB 6kA 1P

## MCB - C Curve

**Type C Curve -** TYPE C instantaneous tripping curve is used for the protection of circuits and equipment that have high surge currents, such as motors.

Devices are designed to trip at fault currents of 5 - 10 times rated (in) for example 10A device will trip instantly at 50 - 100A instantaneous current

Code	Description
<b>PBM06C</b>	6A C Curve MCB 6kA 1P
<b>PBM10C</b>	10A C Curve MCB 6kA 1P
<b>PBM16C</b>	16A C Curve MCB 6kA 1P
<b>PBM20C</b>	20A C Curve MCB 6kA 1P
<b>PBM32C</b>	32A C Curve MCB 6kA 1P
<b>PBM40C</b>	40A C Curve MCB 6kA 1P
<b>PBM50C</b>	50A C Curve MCB 6kA 1P
<b>PBM63C</b>	62A C Curve MCB 6kA 1P

## RCBO - B Curve 1P+N

### Type A RCD -

A type provides protection against residual AC currents and residual pulsating DC currents whether suddenly applied or slowly increasing

### Type B CURVE -

Type B instantaneous tripping curve is used for the protection of circuits and equipment that have low surge currents

Devices are designed to trip at instantaneous fault currents of 3 - 5 times rated (In). For example a 10A device will trip at 30-50A instantaneous current.

Code	Description
<b>PBR06B</b>	6A B RCBO 1P 30mA 6kA Type A
<b>PBR10B</b>	10A B RCBO 1P 30mA 6kA Type A
<b>PBR16B</b>	16A B RCBO 1P 30mA 6kA Type A
<b>PBR20B</b>	20A B RCBO 1P 30mA 6kA Type A
<b>PBR32B</b>	32A B RCBO 1P 30mA 6kA Type A
<b>PBR40B</b>	40A B RCBO 1P 30mA 6kA Type A



## RCBO - B Curve 1P+N with Switch Neutral

Code	Description
<b>PBR206B</b>	6A B RCBO 2P 30mA 6kA Type A
<b>PBR210B</b>	10A B RCBO 2P 30mA 6kA Type A
<b>PBR216B</b>	16A B RCBO 2P 30mA 6kA Type A
<b>PBR220B</b>	20A B RCBO 2P 30mA 6kA Type A
<b>PBR232B</b>	32A B RCBO 2P 30mA 6kA Type A
<b>PBR240B</b>	40A B RCBO 2P 30mA 6kA Type A

## RCBO - C Curve 1P+N with Switch Neutral

### Type C Curve -

Type C instantaneous tripping curve is used for the protection of circuits and equipment that have high surge currents, such as motors

Devices are designed to trip at instantaneous fault currents of 3 - 5 times rated (In). For example a 10A device will trip at 50-100A instantaneous current.

Code	Description
<b>PBR206C</b>	6A C RCBO 2P 30mA 6kA Type A
<b>PBR210C</b>	10A C RCBO 2P 30mA 6kA Type A
<b>PBR216C</b>	16A C RCBO 2P 30mA 6kA Type A
<b>PBR220C</b>	20A C RCBO 2P 30mA 6kA Type A
<b>PBR225C</b>	25A C RCBO 2P 30mA 6kA Type A
<b>PBR232C</b>	32A C RCBO 2P 30mA 6kA Type A
<b>PBR240C</b>	40A C RCBO 2P 30mA 6kA Type A

## SPD TYPE 2

- Surge Protection
- Type 2 SPD
- Replacement module Part Code: **PBSML**
- SPD Kit Part Code: **PBSUWK** - Includes SPD, 32A MCB, connection wires & labels



This unit is a single module but has L (Live), N (Neutral) & PE (earth connections), it uses an MOV across the Live & Neutral and a gas discharge tube across Earth & Neutral to dissipate any voltage spikes.

Code	Description
<b>PBSUWK</b>	SPD Kit with Type 2 SPD, 32A MCB, Connection Wires & Label

Description	PBSUWK		PBSMLWW	
	Type 2 SPD		Type 2 SPD - Replacement module	
Pack Quantity	1		1	
Test Class	Type II		Type II	
Terminal Connections	L - N	N - PE	L - N	N - PE
Rated Working Voltage of Uo (v)	230V~50Hz		230V~50Hz	
Max. Discharge Current Imax 8/20µs	40kA		40kA	
Nominal Discharge Current In 8/20µs	20kA		20kA	
Max. Continuous Operation Voltage Uc	275V	255V	275V	255V
Voltage Protection Level Up	1.5kV		1.5kV	
Short Circuit Current Rating Isccr	500A		500A	
Protection Type	MOV	Gas Discharge Tube	MOV	Gas Discharge Tube
Wiring Capacity	L/N, PE 6mm <sup>2</sup>			
Number of Poles	2		2	
Protection Class	IP20		IP20	
Status Indicator	Green - Normal Red - Failure		Green - Normal Red - Failure	
Mounting	35mm Din Rail		Push fit cartridge	
Casing Material	Thermal Plastic UL94V-0		Thermal Plastic UL94V-0	
Dimensions	L81.6 x W18 x D68.5mm		L46.3x W18 x D49.15mm	
Guarantee	3 Years		3 Years	
Conforms To	EN 61643-11		EN 61643-11	

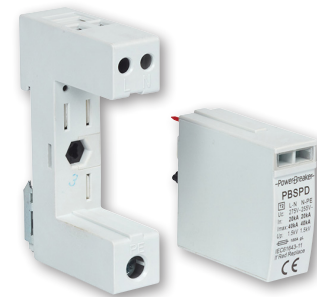

Suitable for TN - (TN-S, TN-C, TN-C-S) and TT

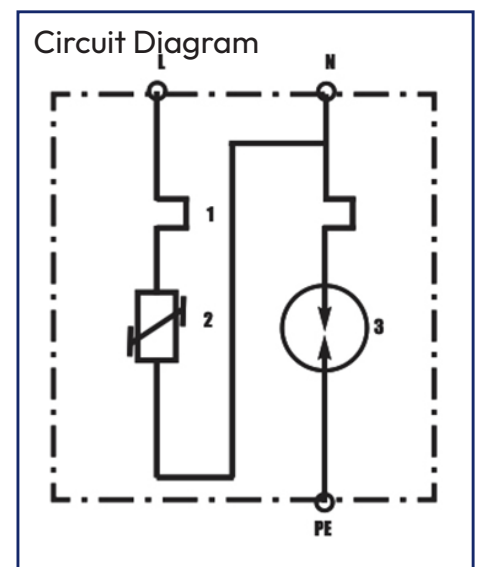

# What are arc faults and what causes them?

An arc fault is an unintentional arcing condition in a circuit. Arcing creates high intensity heating at the point of the arc resulting in burning particles that may over time ignite surrounding material. Repeated arcing can create carbon paths that are the foundation for continued arcing, generating even higher temperatures. The temperatures of these arcs can exceed 6000 °C.

## Development of an arc fault

Arc faults are rarely instant and, depending on a wide number of factors, can take time to develop. The time for an arc fault to form is dependent on its root cause (external influences, ageing, etc.).

Arc faults can occur immediately or over a long period (hours, days, weeks, months, years). With the arc developing, temperatures up to 6000°C can be generated and thus the surrounding insulation starts to burn and eventually a fire develops.

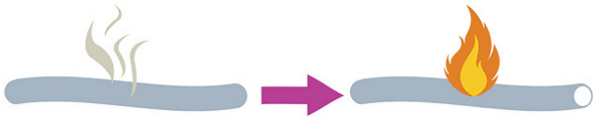

Arc faults can occur in any locations where electrical energy is present with varied root causes, for example:-

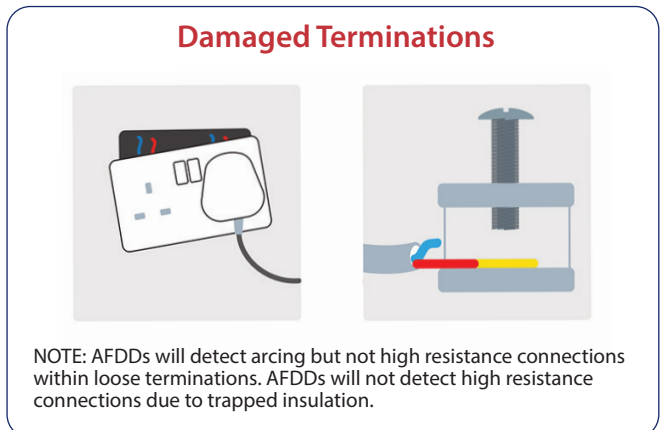
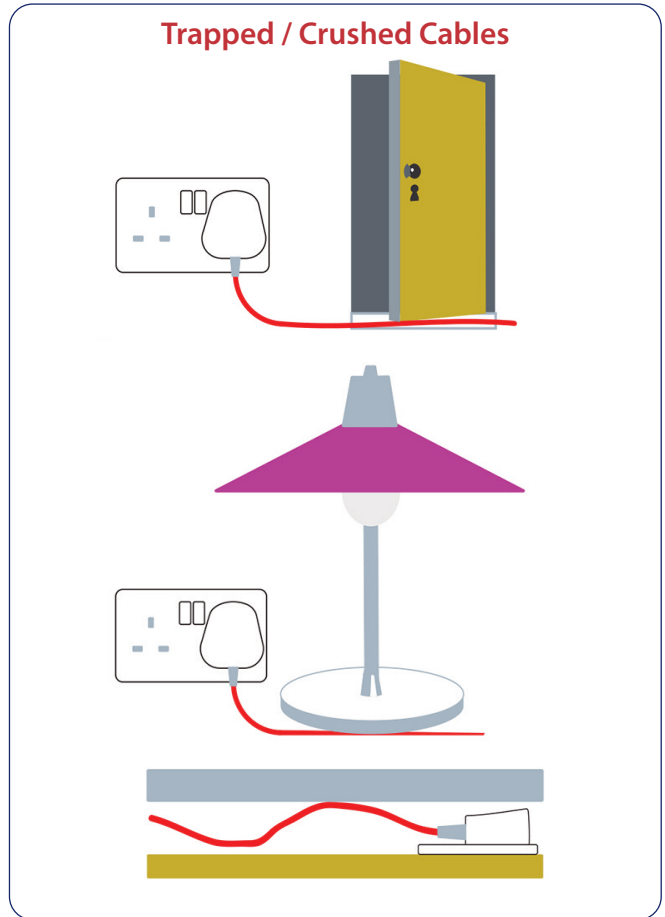
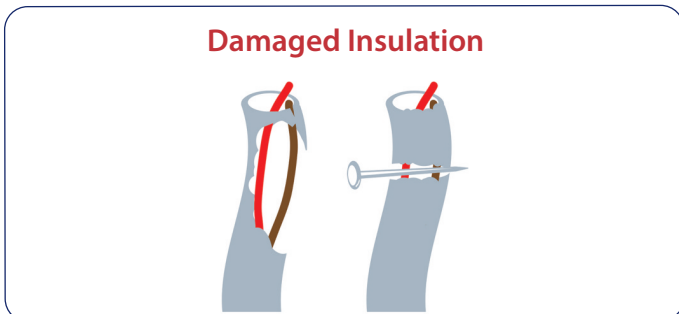
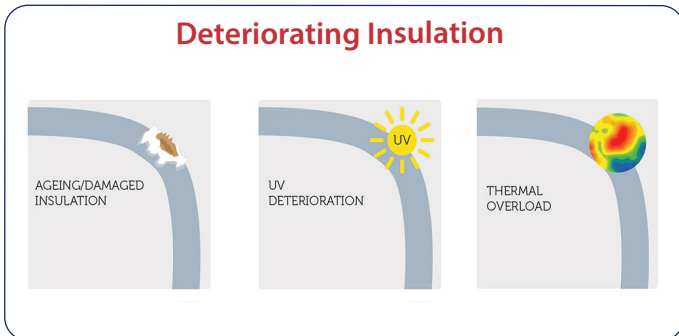
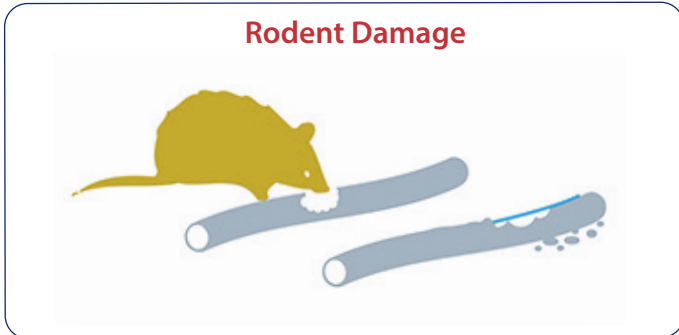
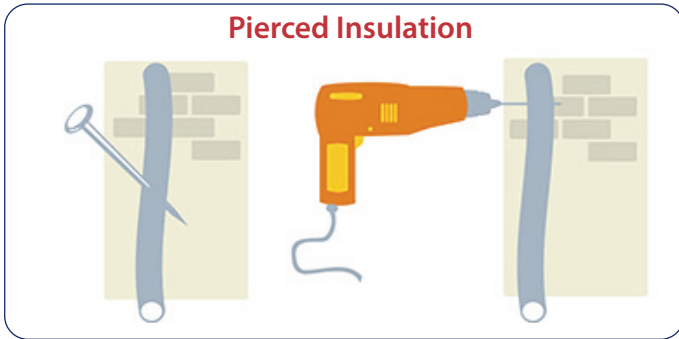

# Types of Arc Fault protected by AFDDs

Originates from

- Damaged cables (e.g. crushed, broken)
- Loose connections

A) A series arc is in series with a load and at a lower level than a parallel arc. The series arc fault characteristics result in the rms value of current of current and  $I^2t$  being too low to operate a fuse or MCB.

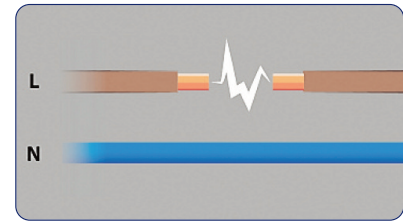

**Protection is provided by AFDDs.**

B) Parallel arc fault current (L-N)

Originates from:

- Fault between L-N
- High impedance due to damaged insulation, fault current is too low to trip other protection devices

Parallel arc fault characteristics (including short duration high peak currents) result in rms,  $I^2t$ , and peak times values that are generally too low to operate protective devices such as fuses or MCBs.

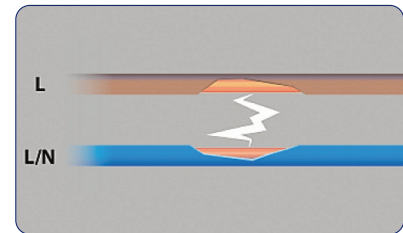

**Protection is provided by AFDDs.**

C) Parallel arc fault current (L-E)

Originates from:

- Fault between L-E
- High impedance due to damaged insulation, fault current is too low to operate circuit breakers or fuses

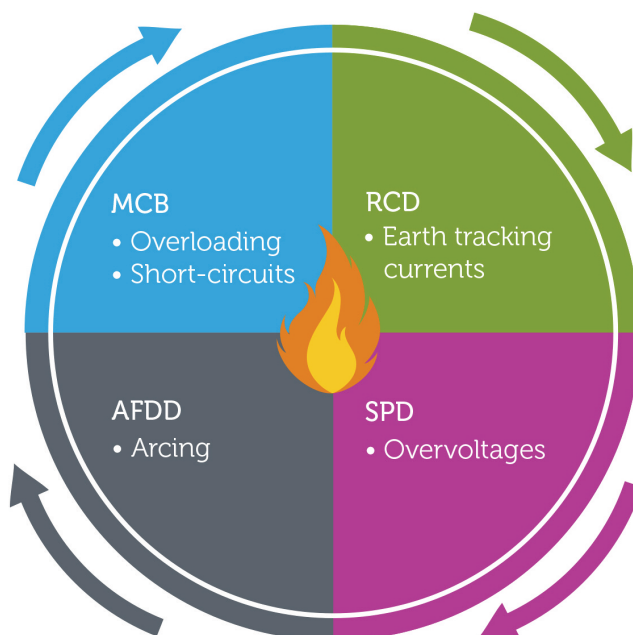
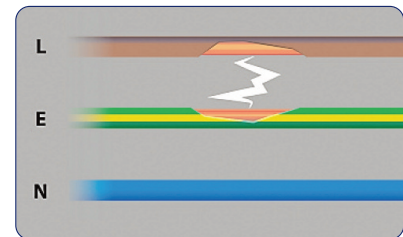

The IET wiring Regulations state the following:-

Arc Fault detection devices conforming to BS EN 62606 shall be provided for single-phase AC final circuits supplying socket-outlets with a rated current not exceeding 32A.

For all other premises, the use of AFDDs conforming to BS EN 62606 is recommended for single phase AC final circuits supplying socket-outlets not exceeding 32A in

- Higher Risk residential buildings (HRRB)
- Houses in Multiple Occupations (HMOs)
- Purpose built student accommodation
- Care homes

# Arc Fault Detection Device with 30mA Type A RCBO instantaneous tripping Curve B

The PowerBreaker range of circuit protection devices are designed and tested for use with PowerBreaker Consumer Units.

**Type A RCD** - A type provides protection against residual AC currents and residual pulsating DC currents whether suddenly applied or slowly increasing

- **Rated Short Circuit Capacity 6kA**
- **1 Pole RCBO + Switch Neutral**
- **Operational Characteristics Type A, 30mA**
- **Instantaneous Tripping B Curve**

Code	Description
<b>PBA06BA</b>	6A Arc fault detection device with 30mA Type A RCBO instantaneous tripping curve B
<b>PBA10BA</b>	10A Arc fault detection device with 30mA Type A RCBO instantaneous tripping curve B
<b>PBA16BA</b>	16A Arc fault detection device with 30mA Type A RCBO instantaneous tripping curve B
<b>PBA20BA</b>	20A Arc fault detection device with 30mA Type A RCBO instantaneous tripping curve B
<b>PBA25BA</b>	25A Arc fault detection device with 30mA Type A RCBO instantaneous tripping curve B
<b>PBA32BA</b>	32A Arc fault detection device with 30mA Type A RCBO instantaneous tripping curve B
<b>PBA40BA</b>	40A Arc fault detection device with 30mA Type A RCBO instantaneous tripping curve B

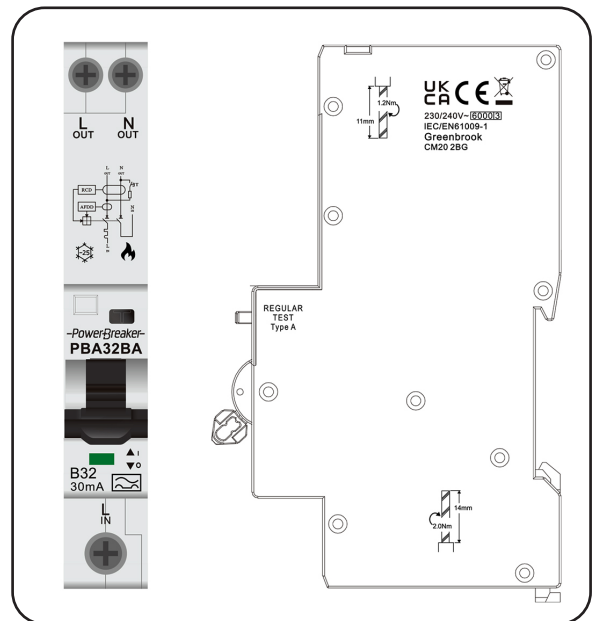

## Type B Curve -

Type B instantaneous tripping curve is used for the protection of circuits and equipment that have low surge currents. Devices are designed to trip at instantaneous fault currents of 3 - 5 times rated (In). For example a 10A device will trip at 30-50A instantaneous current.

Protection Area	
Fault Type	Detected by Integrated
<b>Short Circuit</b>	MCB
<b>Overload</b>	MCB
<b>Residual Current</b>	RCD
<b>Series Arcing Fault</b>	AFD
<b>Parallel Arcing Fault</b>	AFD
<b>Parallel Arcing Fault to PE</b>	RCD
<b>Over Voltage</b>	AFD

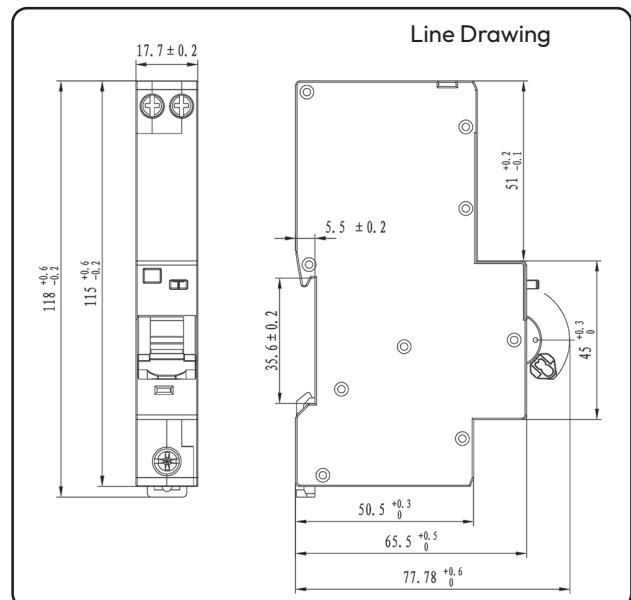

**NOTE:** These devices **MUST** be installed by a qualified electrician in accordance with the latest wiring regulations (BS7671).

# Arc Fault Detection Device Range - Type C Curve

The PowerBreaker range of circuit protection devices are designed and tested for use with PowerBreaker Consumer Units.

**Type A RCD** - A type provides protection against residual AC currents and residual pulsating DC currents whether suddenly applied or slowly increasing

- **Rated Short Circuit Capacity 6kA**
- **1 Pole RCBO + Switch Neutral**
- **Operational Characteristics Type A, 30mA**
- **Instantaneous Tripping C Curve**

Code	Description
<b>PBA06CA</b>	6A Arc fault detection device with 30mA Type A RCBO instantaneous tripping curve C
<b>PBA10CA</b>	10A Arc fault detection device with 30mA Type A RCBO instantaneous tripping curve C
<b>PBA16CA</b>	16A Arc fault detection device with 30mA Type A RCBO instantaneous tripping curve C
<b>PBA20CA</b>	20A Arc fault detection device with 30mA Type A RCBO instantaneous tripping curve C
<b>PBA25CA</b>	25A Arc fault detection device with 30mA Type A RCBO instantaneous tripping curve C
<b>PBA32CA</b>	32A Arc fault detection device with 30mA Type A RCBO instantaneous tripping curve C
<b>PBA40CA</b>	40A Arc fault detection device with 30mA Type A RCBO instantaneous tripping curve C

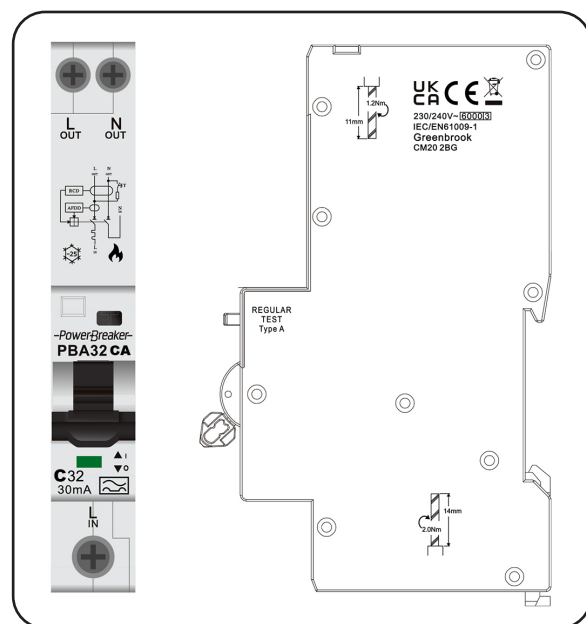

**Type C Curve** - Type C instantaneous tripping curve is used for the protection of circuits and equipment that have high surge currents, such as motors

Devices are designed to trip at instantaneous fault currents of 3 - 5 times rated (In). For example a 10A device will trip at 50-100A instantaneous current

Protection Area	
Fault Type	Detected by Integrated
<b>Short Circuit</b>	MCB
<b>Overload</b>	MCB
<b>Residual Current</b>	RCD
<b>Series Arcing Fault</b>	AFD
<b>Parallel Arcing Fault</b>	AFD
<b>Parallel Arcing Fault to PE</b>	RCD
<b>Over Voltage</b>	AFD

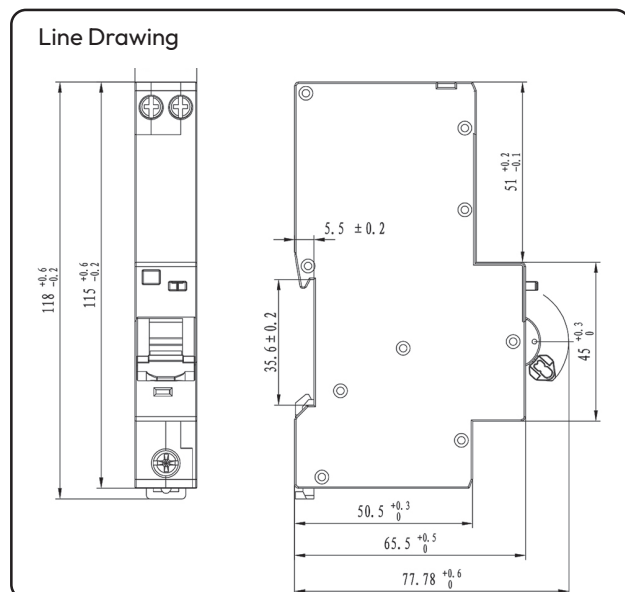

**NOTE:** These devices MUST be installed by a qualified electrician in accordance with the latest wiring regulations (BS7671).

## Contactor

Contactors are electro-mechanically controlled switches used to control high-power loads using a low-power input. These Contactors are frequently used to switch, heaters, fans, lights and pumps.

Code	Description
PBCON20A	20A, 2P, 230V
PBCON40A	40A, 2P, 230V



## Digital DIN Rail Timer Clock

Din rail mount 7 Day Programmable timer with Digital Display. 16 Amp rated with change-over contacts

- 7 Day Programmable with Digital Display Time Switch
- 16A

Code	Description
PBDTC	16A, Digital Time Switch



## Mains Isolator Switch

- Rated Short Circuit Capacity 6kA
- 100A
- Double Pole



	PBI
Rated Residual Current	100A
Pack Quantity	6
Number of Poles	2P (Double Pole)
Rated Voltage	230/240VAC
Rated Frequency	50/60Hz
Terminal Capacity	1 - 35mm <sup>2</sup>
Mechanical Endurance	10,000 times
Electrical Endurance	4,000 times
Ambient Temperature	- 25°C to +55°C
Storage Temperature	- 40°C to +70°C
Torque (Recommended minimum tightening)	2.5Nm
Din Rail Mounting	Yes
Guarantee	3 Years

# Accessories



## Cable Clamp

Code	Description
PBCC	Cable Clamp

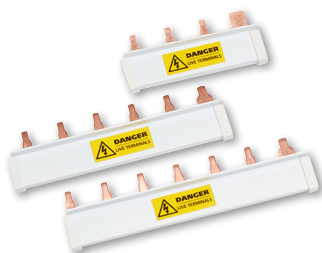

## Module Busbar

Code	Description
PBB8	8 Module Busbar
PBB12	12 Module Busbar
PBB16	16 Module Busbar
PBB21	21 Module Busbar



## Blank Module

Code	Description
PBMBB	Blank Module



## Oval Module Knock Out

Code	Description
PBOMKO	Oval Module Knock Out

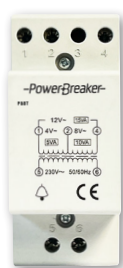

## Bell Transformer

Code	Description
PBBT	Bell Transformer - 4/8/12 VOLTS



## Tail Glands 32mm

Code	Description
PBTCG32	32mm Tail Gland

Our tail glands meet current regulations for metal consumer units. The tail kit design allows meter tails and the earth wire to enter the consumer unit to be installed through one insert. They provide the required cable retention and help to maintain the appropriate fire integrity of the consumer unit. They also provide anti vibration protection, are easy to assemble and are halogen free.

# Dimensions

## 8 - 10 Way Dimensions

For Consumer Unit - PBPM08 & PBPM10 / PBPM08-SPD & PBPM10-SPD

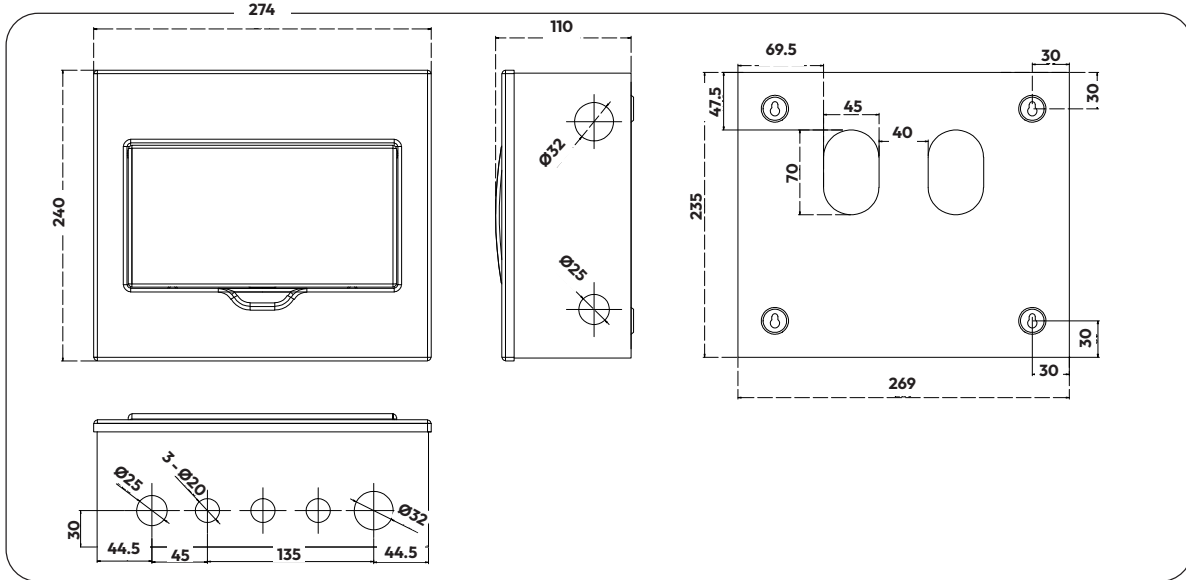

## 12 - 14 Way Dimensions

For consumer Unit - PBPD12 / PBPD14 / PBPM12 / PBPM14 / PBPM12-SPD / PBPM14-SPD

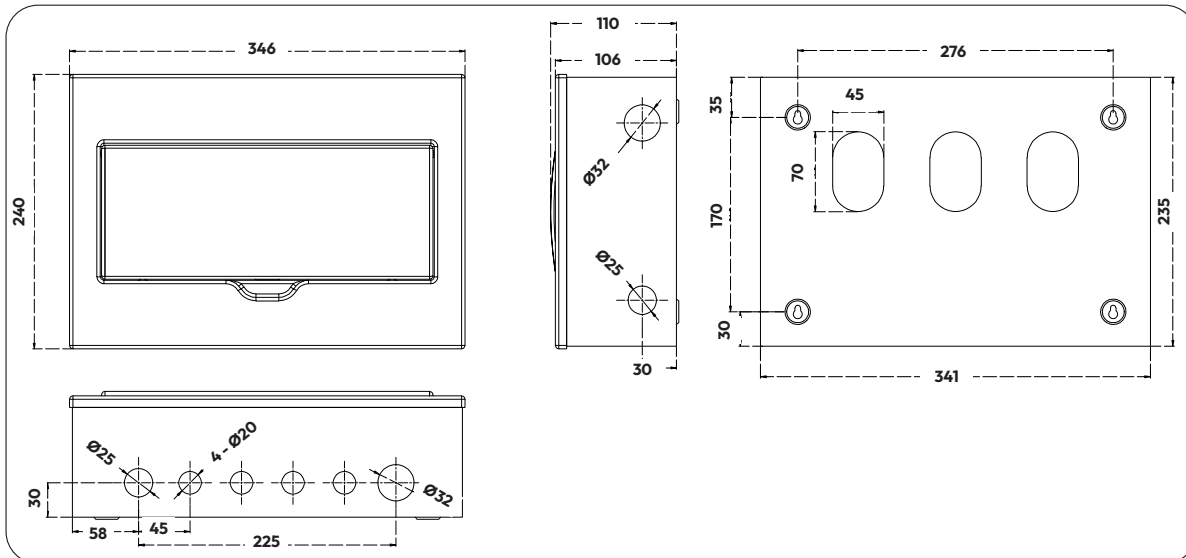

# Dimensions

## 16 - 18 Way Dimensions

For consumer Units - PBPD16 / PBPD18 / PBPDM16 / PBPDM18 / PBPDM16-SPD / PBPDM18-SPD / PBPM16 / PBPM18 / PBPD16 / PBPD18 / PBPM16-SPD / PBPM18-SPD / PBPD16 / PBPD18

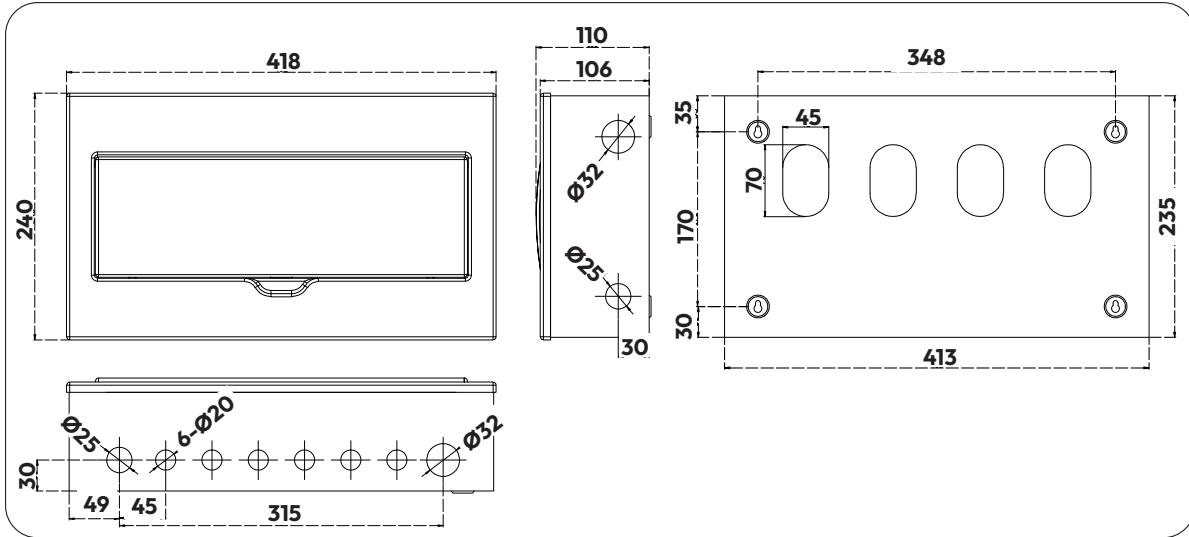

## 20 - 22 Way Dimensions

For consumer Unit - PBPD20 / PBPD22 / PBPDM20 / PBPDM22 / PBPDM20-SPD / PBPDM22-SPD / PBPM20 / PBPM22 / PBPD22 / PBPH18 / PBPH22 / PBPM20-SPD / PBPM22-SPD

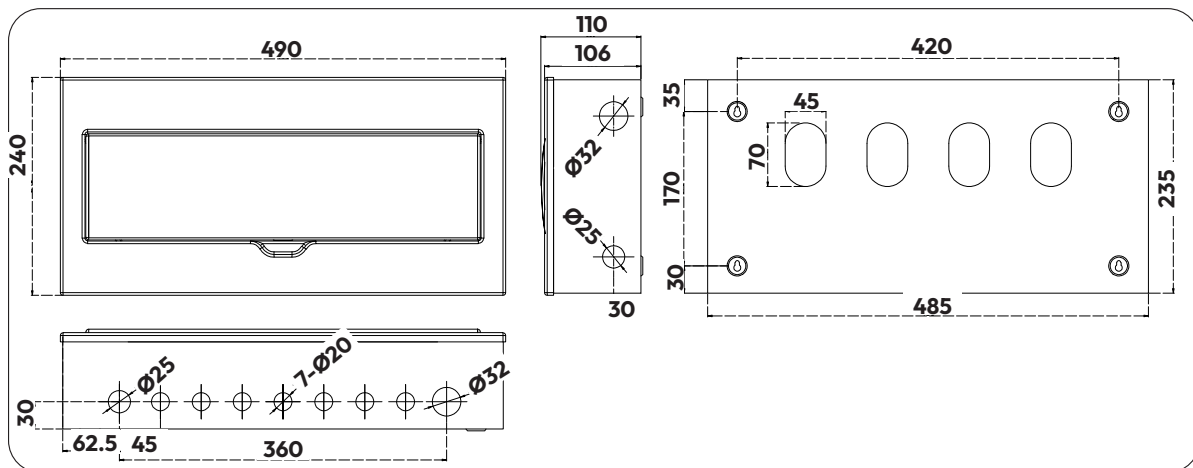



# Dimensions

## 40 - 44 Way Dimensions

For consumer Units - PBDS44 / PBDS44-SPD

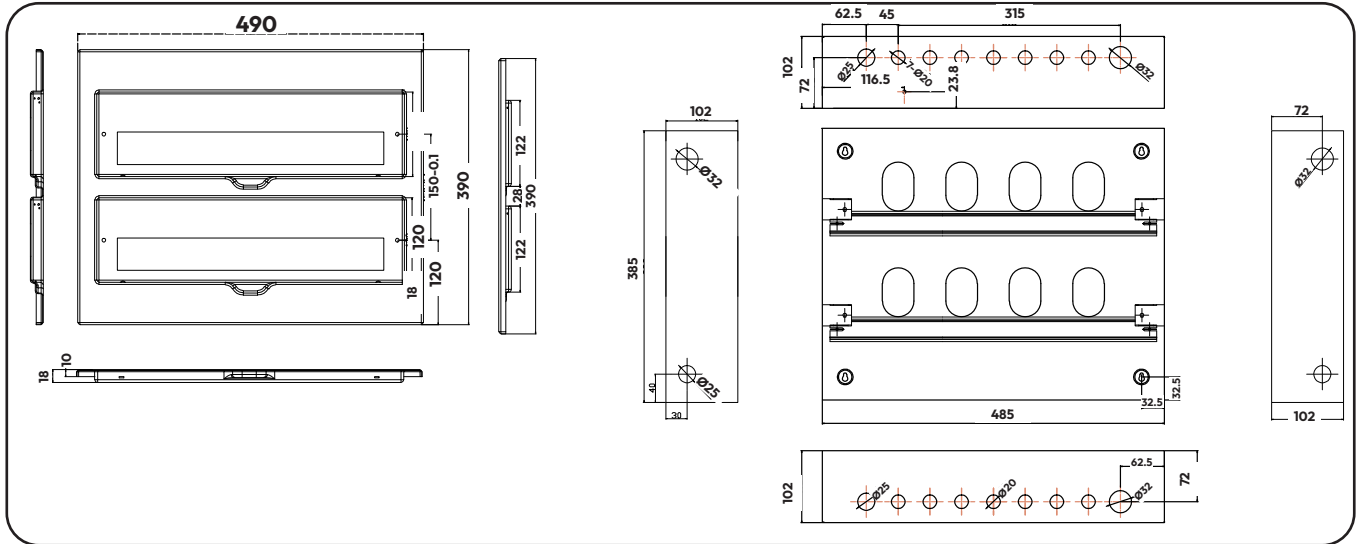

### B Curve

PBA06BA, PBA10BA, PBA16BA, PBA20BA, PBA25BA, PBA32BA, PBA40BA

### C Curve

PBA06CA, PBA10CA, PBA16CA, PBA20CA, PBA25CA, PBA32CA, PBA40CA

