

powerbreaker RCD Fused Connection Units

10mA Passive

TECHNICAL
DATA SHEET

PRO
SERIES

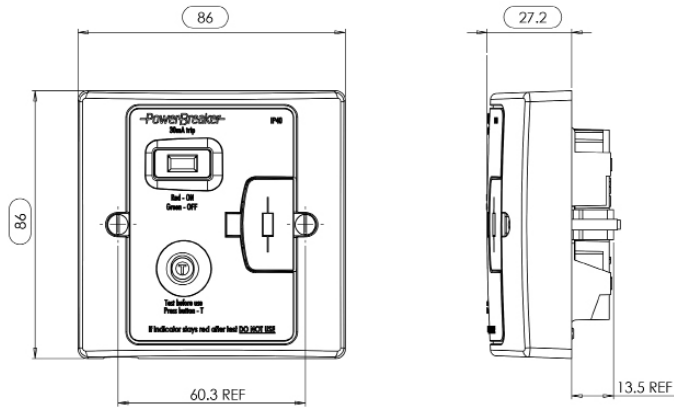

H92-WP10 RCD FUSED CONNECTION UNIT - WHITE

TYPE A RCD
BS 7288-2016+A1:2022
10mA

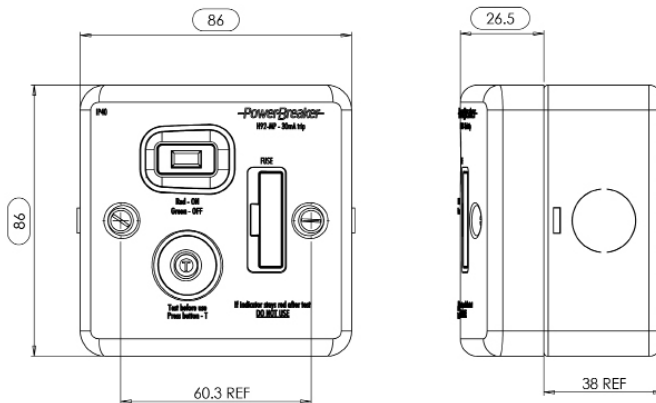

H92-MP10 RCD FUSED CONNECTION UNIT - METAL

FEATURES

- ▶ Mechanically latched (does not need resetting after a power loss)
- ▶ Red & Green dual flag system to show power on/off
- ▶ High intensity LED power on indicator
- ▶ Cuts the power for added protection against electrocution
- ▶ Fused for all fixed electrical appliances

TECHNICAL INFO

| Product | H92-WP10 | H92-MP10 |
|--|--|-----------------------|
| Product Finish | White | Metalclad |
| Barcode | 5012739 646935 | 5012739 646942 |
| Product Weight | 195g | 392g |
| Product Dimensions | 86 x 86 x 27.2mm | 86 x 86 x 26.5mm |
| Voltage | 230V AC ~ 50Hz | |
| Max Operating Current | 13A (13A Inductive) | |
| IP Rating | IP40 | |
| Rated Trip Current | 10mA | |
| Typical Trip Speed | Less than 20mS (typical) | |
| RCD Contact Break | Double pole | |
| Terminal Capacity | 6mm ² max | |
| Rated Short Circuit Breaking & Making Capacity | 250A | |
| Rated Conditional Short-Circuit Current | 1500A Power Factor Range .93 to .98 | |
| Latching | Mechanical - No need to reset after a Power Loss (Passive) | |
| Responsive To | Pulsating DC earth faults | |
| Main Housing Material | Urea | Steel & Polycarbonate |
| Cord Anchorage | Cable Dia: 4.6mm - 10.4mm Cable Size - 0.5mm ² to 1.5mm ² | |
| Guarantee | 3 Years | |
| Conforms To | BS 7288-2016+A1:2022, BS1363-4:2016+A1:2018 | |