

**7 DAY
ELECTRONIC
PLUG-IN
TIMER**

Part No: T17B

in@chronox

PRO by **GREEN**
SERIES **BROOK**

Please read the instructions fully before attempting operation.

TIMER INFORMATION

- Timer uses a standard AAA size non-rechargeable battery to back up the timer memory function. The battery allows for programming while the unit is not plugged in and provides for memory retention during power failures. The battery back up will last at least 150 hours.

CURRENT TIME AND DAY SETTING

1. There are 24 ON/OFF programmes available.
2. Press the Y button twice to enter the programme setting mode.
(Note: If another button is not pressed within 10 seconds the display will revert to the normal screen)
3. Default is programme 01 ON, this can be changed if required by pressing the + or - button to scroll through the 24 ON/OFF programmes as required, pressing the Y will confirm the programme.
4. Press the Y button to confirm programme 01 ON, hours will flash.
5. Use the + or - button to adjust the hours and press Y to confirm, minutes will flash.
6. Use the + or - button to adjust the minutes and press Y to confirm, days will flash.
7. Apart from individual days of the week, the following day combinations of multiple day blocks can be selected by pressing the + or - buttons.
 - Monday to Sunday
 - Monday to Friday
 - Saturday & Sunday
 - Monday to Saturday
 - Monday + Wednesday + Friday
 - Tuesday + Thursday + Saturday
 - Monday + Tuesday + Wednesday
 - Thursday + Friday + Saturday
8. Select day or day block as required and press the Y button to confirm.
9. Press the + button, this will select the programme 01 OFF, press Y to confirm.
10. Follow 4 to 7 above to set the 01 OFF programme. (day or day block must be the same as programme ON).
11. If no more programmes are required, press the N button to exit.
12. If more programmes are required, follow 3 above.
13. To cancel a programme once set, press and hold the N button for more than 3 seconds when the desired programme number is flashing, i.e. to cancel programme 01 ON, press the Y button twice and hold the N button down for more than 3 seconds to delete. Pressing the + button again will select the 01 OFF.
14. Repeat 13 to delete 01 OFF. This procedure can be repeated to delete any of the 24 programmes.



TIMER COUNTDOWN FUNCTION

1. Timer has a 100 hour countdown feature i.e. The timer can be set to any period from 1 minute to 100 hours and will countdown in the ON state and turn OFF at the end of the countdown period.
2. Press the Y button then use the + or - button to select the "down" icon on the right hand side of the display, press Y again to enter the countdown mode.

- Use the + or - button to adjust the hours and press Y to confirm, minutes will flash.
- Use the + or - button to adjust the minutes and press Y to confirm and complete the countdown time setting.
- Press the N button to start the countdown.
- Output switched to ON during the count down period.
- Press the N button to pause the countdown (output switched to OFF).
- To resume countdown simply press the N button again.
- Press and hold the N button for more than 3 seconds to exit the countdown function.

MANUAL OVERRIDE

When in normal clock mode, pressing the N button will scroll through the following switching options.

- ALWAYS ON - Timer is permanently ON.
- PROG  - Timer is in programme ON mode, will switch off at the next programme OFF time.
- ALWAYS OFF - Timer is permanently OFF.
- PROG  - Timer is in programme OFF mode, will switch on at the next programme ON time.

SUMMER TIME SETTING

- Press the Y button, then use the + or - buttons to scroll through to “summer” (flashing).
- Press the Y button again to access the summer time setting.
- Press the + or - button to change between summer on or off.
- Press Y to confirm summer setting, time will advance 1 hour.
- A “SUMMER” icon will appear in the display.
- Use the same procedure to remove the “SUMMER” icon when reverting to GMT in the winter.

READING YOUR PROGRAMMED TIMES

- Press Y button twice to enter programme mode.
- Press the + or - buttons to scroll through the 24 ON/OFF programmes to check settings.
- Press the N button to exit and revert to clock mode.

RESET

Pressing the reset button R with a pencil or similar will reset all programmed times and set time of day to zero.

BATTERY REPLACEMENT

Note:

Green battery shims will be in T17B timer stock from April 2024 only.

If the display disappears when the timer is unplugged or during a power failure the AAA battery needs replacing.

Remove the battery cover at the top rear of the timer and replace battery with a new AAA non-chargeable battery.

The two plastic green shims over battery clips need to remain in place.

Ensure that the battery polarities (+and-) match those inside the battery compartment. Replace into timer and check display. Current time of day and programmes can now be entered.

IMPORTANT:

When you have completed the programme setting ensure you set correct operating mode as shown in manual override.

TECHNICAL INFORMATION

Rated Voltage:	230V, AC 50Hz
Switching Capacity:	13A Resistive, 2A Inductive
Battery Back Up:	150+ Hours
Shortest Switching Time:	1 minute
Programmable:	Every minute
Wattage:	3000W
Dimensions:	H123 x W64 x D50mm
Conforms To:	BS EN 1363 & EN 60730-2-7

DIMENSIONS

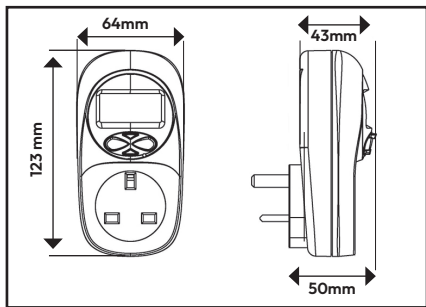

NOTE:

Product & Packaging Disposal

When disposing of this item and its packaging please follow local regulations and use an appropriate waste disposal centre. See GreenBrook website for further details.

GUARANTEE

Your 7 Day Electronic Plug-in Timer is guaranteed for 1 year from the date of purchase. This is in addition to your statutory rights.

PLEASE KEEP THESE INSTRUCTIONS SAFE FOR FUTURE REFERENCE