

Waterproof Plug and Socket Cable Connector Wiring Instructions

WIRING INSTRUCTIONS

1. Twist connector anti-clockwise about 45° using pliers and pull out of body noting guide ribs. See Dia.1.
2. Push cable through gland entry and into body. (DO NOT disassemble gland). See Dia.2.
3. Strip cable sheath 25mm, strip lead insulation 6mm. Markings on alignment ribs are a guide.
4. Fit leads to terminals ensuring screws are fully tightened. BROWN to "L", BLUE to "N" GREEN/YELLOW to \perp .
5. Re-fit connector by aligning slots in connector with guidance ribs in body, push in then twist clock-wise 45° until stop is reached and the connector clicks into place. See Dia.3.
6. Tighten gland nut hand tight then one turn with a spanner (at least 2Nm torque).
7. Repeat for other half. See Dia.4.

NOTE

TO MATE: Line up alignment ribs then push bodies FIRMLY together until latches FULLY click into engagement.

TO UNMATE: Pull and hold back collar in direction of arrow to unlock then separate bodies.

WARNING

- + Isolate from the mains before fitting, mating or unmating.
- + Ensure everything is clean and dry before use.
- + If in doubt please consult a qualified electrician.

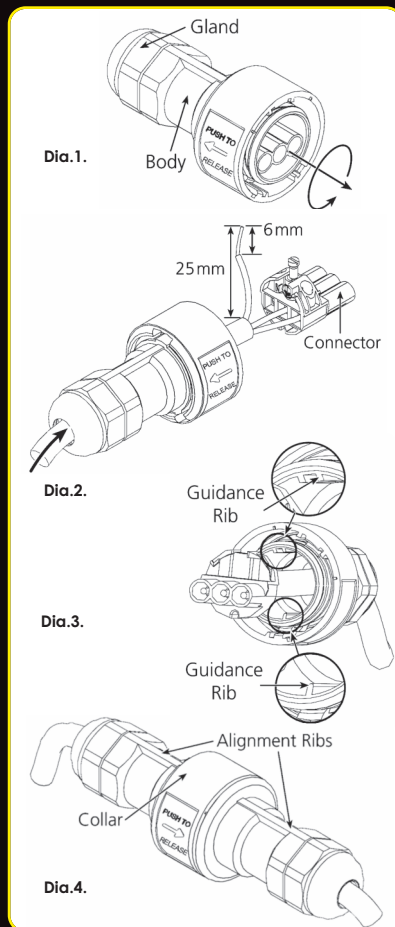

Please keep these instructions safe for future reference